

Dutchess

Bakers' Machinery Company, Inc.

A subsidiary of Superior-Lidgerwood-Mundy Corp.

*A United States of America Manufacturer
Since 1886*

Item No. _____

Model JN

Semi-Auto Dough Divider/Rounder
(1 ounce to 26 ounce total capacity)

Semi-Auto Dough Divider/Rounder

4 Machines in one Capability!

Interchangeable head assemblies in either 36, 18, 9 or 6-part divisions allow fast accurate scaling and rounding of dough in weights ranging from 1 ounce up to 26 ounces each piece.

Examples: 36-part = 1 - 2-3/4 ounces each
18-part = 2 - 7 ounces each
9-part = 7 - 18 ounces each
6-part = 18 - 26 ounces each

When removed for cleaning or interchange (*no tools required*), the entire head assembly can be placed into a sink or dishwasher for complete cleaning to a sanitary operating condition in just minutes per day.

Capable of dividing and rounding many types of Yeast Raised Dough including Bread & Bun dough, Tortilla & Pizza dough.

Simple to operate - learn in just minutes!

Training Video & Manual are provided.

Two year warranty.



NSF (National Sanitation Foundation Intl.)

USDA (United States Dept. of Agriculture)

UL (Underwriters Laboratories)

ASSOCIATE MEMBER
MAFSI
Manufacturers' Agents for
the Food Service Industry

Dutchess Bakers' Machinery Co.
302 Grand Avenue, PO Box 39
Superior, WI 54880-0039

(AP-2000-7/05) **ISO 9000:2001 COMPLIANT**

Toll Free: 800-777-4498
Phone: 715-394-4444
Fax: 715-394-2406
sales@dutchessbakers.com
www.dutchessbakers.com

MODEL JN

Semi-Auto Dough Divider/Rounder

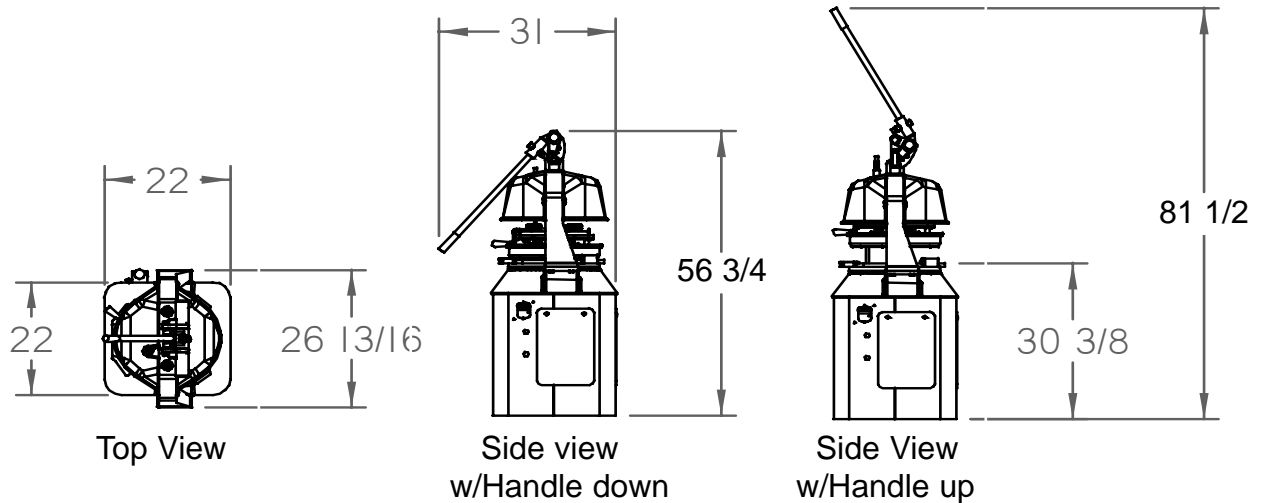

Machine Dimensions:

Width: 26 13/16" (68.07 cm) **Depth:** 22" (55.88 cm) **Height:** (incl. handle) 81 1/2" (207.6 cm)

Shipping Wt.: 490 lbs.(220.5 kg) **Net Wt.:** 449 lbs (202 kg)

Shipping Class: 85 **FOB:** Superior, WI 54880

Shipping Dimensions: 28-1/4" x 25-1/2" x 66" (71.75 cm x 64.77 cm x 167.64 cm)

Standard:

36-Part Head Assembly (P/N C4-436-0053), (2) 36-Part Dough Pallets, White Powder Coated Finish, 2-year warranty, Training Video, Manual
208v / 60hz / 3-phase, 3/4 hp motor, 10 amps required.

Options:

120 or 240v / 60 hz / 1-phase, 1-hp or 460v / 60 hz / 3-phase **(50 hz also available)**

18-Part Head Assembly (P/N C4-436-0051) Includes two same division Dough Pallets.

9-Part Head Assembly (P/N C4-436-0049) Includes two same division Dough Pallets.

6-Part head Assembly (P/N C4-436-0055) Includes two same division Dough Pallets.

Dutchess Bakers' Machinery Company Inc., 302 Grand Avenue, Superior, WI 54880-0039

Toll Free: 800-777-4498 ~ Ph: 715-394-4444 ~ Fax: 715-394-2406

sales@dutchessbakers.com ~ www.dutchessbakers.com