



BEVERAGE-AIR

PO Box 5932, Spartanburg, SC 29304
1-888-845-9800 Fax# 1-864-582-5083
<http://www.Beverage-Air.com>

Commercial Refrigeration Equipment General Specification

DMC SERIES—HORIZONTAL DISPLAY CASES

Versatile, horizontal display cases for displaying specialty foods, deli items and beverages. DMCS models are equipped with front sliding, triple pane tempered glass doors for easy customer access.

CABINET CONSTRUCTION

Heavy duty construction includes exterior of heavy duty, white coated steel and white aluminum interior sides. Steel and covered corner stainless steel floor for easy cleaning and complete with drain and hose connection at lower rear of cabinet 2" from the floor. Stainless steel top standard. Stainless steel exterior option available.

Cabinet front on DMC models are supplied with a large triple pane tempered glass window with fluorescent light interior for easy product viewing. DMCS models are equipped with front sliding, triple pane tempered glass doors for easy customer access.

Stainless steel mezzanine shelves included are adjustable to either a slanted or leveled position. Optional shelf light is available.

Units feature lower storage area accessible through a solid hinge door at bottom rear.

Cabinet insulation is CFC and HCFC-free foamed-in-place polyurethane of two-inch minimum thickness.

REFRIGERATION

Equipped with a gravity coil refrigeration system complete with automatic defrost clock to enhance the preservation of meat and deli product. Systems are designed using CFC and HCFC-free R134a refrigerant.

ELECTRICAL

All models require a hard wire connection. Accessory plug and light switches (115 volts).

Item No. _____
Quantity _____

HORIZONTAL DISPLAY CASES DMC SERIES

MODELS:
DMC4/DMCS4
DMC6/DMCS6
DMC8



DMC6 (white exterior shown)

Available From:



*Note: Not all markings may apply to all model variations.

Model Specified _____	Store# _____
Location _____	Quantity _____



BEVERAGE-AIR

PLAN VIEWS

Horizontal Display Cases

Models: DMC4/DMCS4, DMC6/DMCS6, DMC8

MODEL	DMC4/DMCS4	DMC6/DMCS6	DMC8
EXTERNAL DIMENSIONAL DATA			
Length Overall (inches)	48"	72"	96"
Length Overall (mm)	1219	1829	2438
Depth Overall (inches)	36 1/2"	36 1/2"	36 1/2"
Depth Overall (mm)	927	927	927
Height Overall— (inches)	54"	54"	54"
Height Overall— (mm)	1372	1372	1372
Display window size	29 3/4" x 45"	29 3/4" x 67"	29 3/4" x 93"
INTERNAL DIMENSIONAL DATA			
NET Capacity (cubic ft.)	27.7	45.8	63.9
NET Capacity (Liters)	784	1297	1810
Number of shelves	1 each	2 each	2 each
ELECTRICAL DATA			
Full Load Amperes 115/60/1	7.2	12	10.5
REFRIGERATION DATA			
Horsepower	1/3	1/3	1/2
WEIGHT DATA			
Gross Weight (Crated lbs)	482	610	805
Gross Weight (Crated kg)	219	277	365

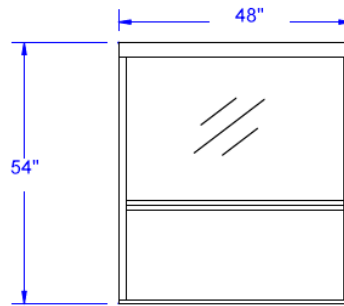

**FRONT
DMC4**

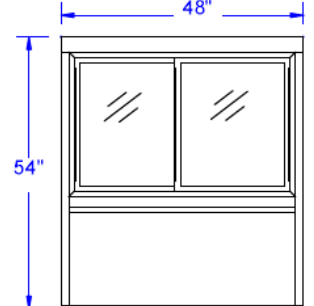

**FRONT
DMCS4**

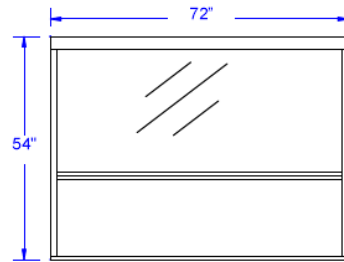

**FRONT
DMC6**

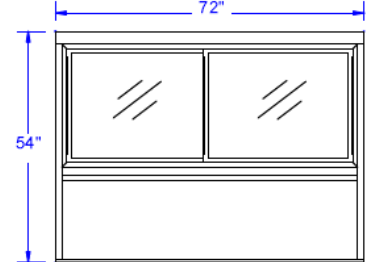

**FRONT
DMCS6**



Note: Not all markings may apply to all model variations.

*N/A.: Not available at time of printing.

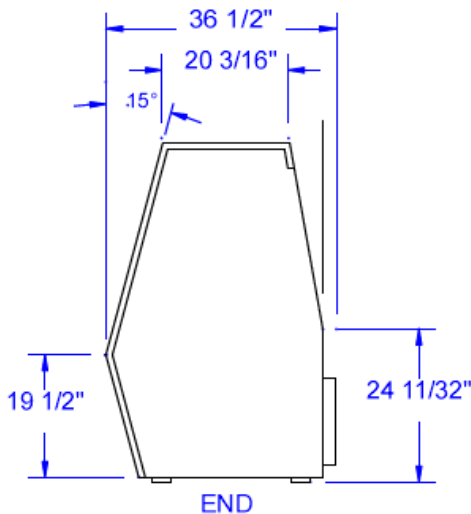

END

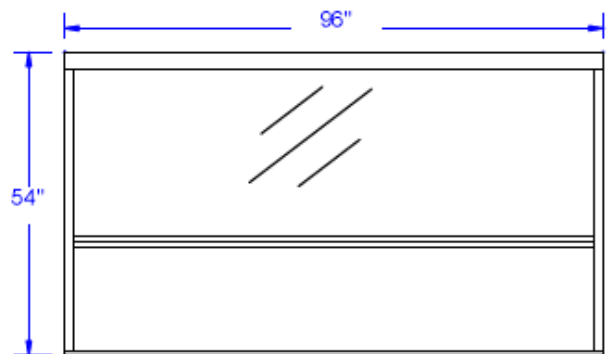

**FRONT
DMC8**

BEVERAGE-AIR® CORPORATION

700 Buffington Road • PO Box 5932 • Spartanburg, SC 29304 USA • (864) 582-8111 • Fax (864) 582-5083 • (888) 845-9800 • www.beverage-air.com

Specifications are subject to change without prior notice. 07/09