



Conveyer Toaster

SFE02700-120

Dimensions: Height: 16 1/2" (412 mm)
Width: 11 1/2" (287 mm)
Depth: 15" (375 mm)

Shipping Weight: 41 lbs (18.6 Kg)

Volt: 120 **Watts:** 1800 **AMP:** 15

Mx Capacity: 300 slices/hr

SFE02710-240

Dimensions: Height: 16 1/2" (412 mm)
Width: 14 1/2" (362 mm)
Depth: 15" (375 mm)

Shipping Weight: 45 lbs (20.5 Kg)

Volt: 220 **Watts:** 2600 **AMP:** 12

Mx Capacity: 500 slices/hr

SFE02720-240

Dimensions: Height: 16 1/2" (412 mm)
Width: 18 1/2" (462 mm)
Depth: 15" (375 mm)

Shipping Weight: 50 lbs (22.7 Kg)

Volt: 220 **Watts:** 3200 **AMP:** 15

Mx Capacity: 700 slices/hr



Features

- High output conveyer toasters
- Front or rear exit capabilities
- Speed & temperature controls
- Stainless steel construction
- Large opening for bagels
- ETL + NSF Approved

Electrical Diagrams

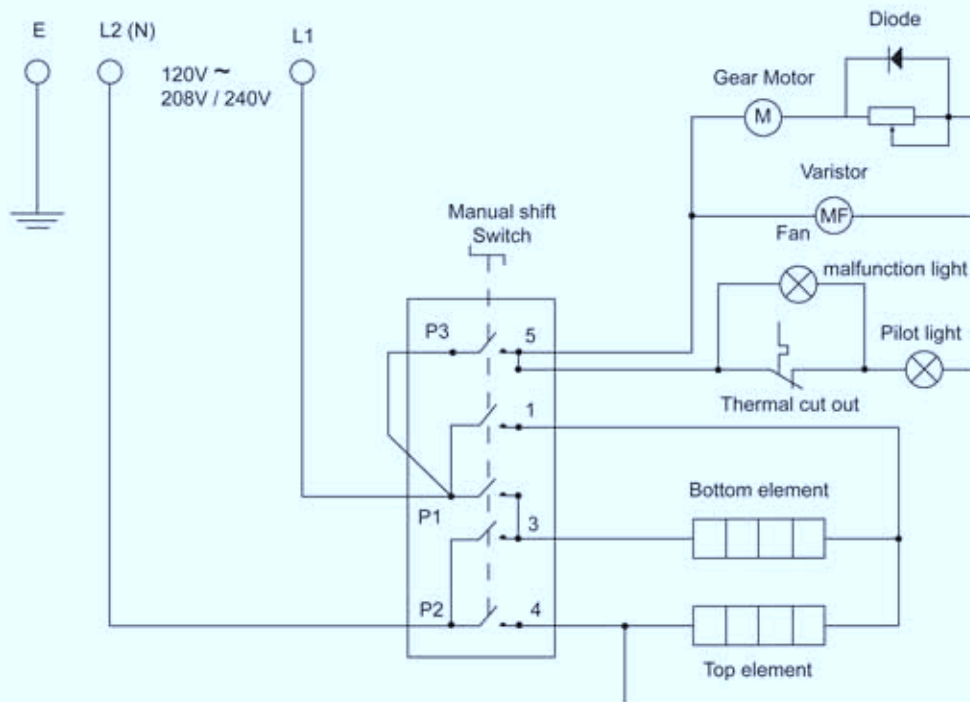

The above circuit diagram has been provided to assist qualified technicians, Eurodib agents or Recommended Qualified Technicians should carry out repairs if needed. Do not remove any components or service panels on this product.



Po Box 1798, 1320 Route 9, Champlain, NY, 12919, USA
120 de la Barre, Boucherville, Qc, J4B 2X7, Canada
Toll free Ph) 888-956-6866 Fax) 877-956-6867
www.eurodib.com