

Project _____

Item # _____

Quantity _____



GLOBE FOOD EQUIPMENT COMPANY

Manual Slicer

3600P



3600P Manual Slicer

Model

- 3600P - Manual Slicer

Features a 13" PreciseEdge™ knife, a premium gear drive system, stainless steel construction, and Globe's exclusive EZ-Glide™ system.



Made in the U.S.A.



Standard Features

- Exclusive stainless steel construction
- EZ-Glide™ chute and slice table system
- 13" PreciseEdge™ hardened steel alloy knife
- Powerful 1/2 HP, 7 amp motor
- Premium gear driven knife
- Maintenance-free drive system
- Built in antimicrobial protection
- Precision gear slice thickness adjustment
- Open space base design
- Knife cover interlock
- Signature knife sharpening system
- Permanently attached knife ring guard
- Full gravity feed, 45° angle
- 3 lb. stainless steel endweight
- Cleaning brace
- Power indicator light
- No voltage release

Options and Accessories

- Quick-Clean™ proprietary nickel-based coating (knife cover and slice table)
- Front mounted endweight assembly
- Unique dual arm lift lever
- Prison package
- High moisture application package (includes stainless steel knife)
- 15" long food chute
- Stainless steel knife
- Endweight with meat prongs
- Low food fence (12"L x 1 3/8"H)
- High food fence (12"L x 3"H)
- 3" extension legs
- 10 lb. attachable portion control scale
- Vegetable hopper
- Clear plastic slicer cover

Standard Warranty

- Two-years parts and one-year labor plus 15 years on the knife drive gears

Approved By: _____

Date: _____



GLOBE FOOD EQUIPMENT COMPANY

www.globeslicers.com

2153 Dryden Rd.
Dayton, OH 45439
Phone: 937-299-5493
Phone: 800-347-5423
Fax: 937-299-4147



Manual Slicer

3600P

Specifications

Finish: Exclusive all stainless steel base with radiused corners improves sanitation and durability. Other stainless steel parts include the food chute, slicing table, endweight and knife cover.

Knife Motor: Powerful 1/2 HP, 7 amp, 115/60/1, air cooled, permanently lubricated sealed ball bearings. Solid state start relay.

Knife Drive: Cross axis helical gear drive design. This maintenance free drive design is continuously lubricated ensuring quiet operation and reliable cutting performance.

Slice Thickness: Precision dual gear design eliminates table movement during slicing. Consistently produces tissue thin slices with a maximum slice thickness of 1 1/4" thick.

Antimicrobial Protection: Knobs and handles have antimicrobial protection built in, which inhibits the growth of bacteria and provides superior sanitation.

Full Gravity Feed: Full 45° angle feed requires less mechanical pressure. Equipped with a 3 lb. stainless steel endweight to minimize waste and hold product. Food chute handle is ergonomically designed and the endweight swings away for storage behind the chute.

EZ-Glide™ Slicing System: Specially engineered chute gliding system and slice table provides minimal food contact on table for smooth and effortless slicing.

Cleaning Brace: A metal brace under the slicer drops into position, tilting the slicer to facilitate safe and easy cleaning underneath the slicer.

Knife Cover Interlock: Slicer will not operate with knife cover removed.

Knife Ring Guard: Permanently mounted knife ring guard covers the non-slicing portion of the knife protecting the operator from the knife's edge.

Top Mounted Sharpener: Metal knife sharpener is permanently mounted on the slicer. A single lever activates the stones to quickly and easily return a razor sharp cutting edge.

Hollow Ground Knife: 13" diameter special hardened steel alloy knife with stain resistant finish and sanitary hub provides increased cutting capacity, clean cuts and effortless slicing. Knife's edge has a Rockwell hardness of 60-62.

No Voltage Release: Prevents inadvertent reactivation of slicer in the event of power or interlock interruption.

Cutting Capacity: Width 11.6" (29.5 cm), Height 9" (22.9 cm), Diameter 7.5" (19 cm)

On/Off Tab: Moisture protected toggle type, operated by a push-pull rod.

Power Indicator Light: A readily visible orange light illuminates when the knife is rotating.

Cord & Plug: Attached 7 foot flexible 3 wire cord with molded plug fits a grounded receptacle.

Dimensions:

Foot Print = 14" x 21.6"
(35.6 cm x 54.9 cm)
Overall Length = 26.2" (66.5 cm)
Overall Width = 22" (55.9 cm)
Overall Height = 21.1" (53.6 cm)
Freight Class: 77.5
Net Weight: 112 lbs. (50.8 kg)
Shipping Weight: 132 lbs. (59.9kg)
Shipping Dimensions:
28"W x 25"D x 28"H
(71.1 cm x 63.5 cm x 71.1 cm)

Factory Installed Options:

Quick-Clean™ Quick-Clean™ proprietary nickel-based coating (knife cover, slice table)
FMEW Front mounted endweight
LEVER Dual arm lift lever
PRISON Prison package
MEATROOM High moisture application package
LONGCHUTE 15" long food chute
SSK Stainless steel knife
PRONGS Endweight with meat prongs

Accessories:

1326 High fence (12" x 3")
1047 Low fence (12" x 1-3/8")
873-SET 3" extension legs
10 lb. attachable portion control scale
699-BAS Vegetable hopper
SC-LARGE Clear plastic slicer cover

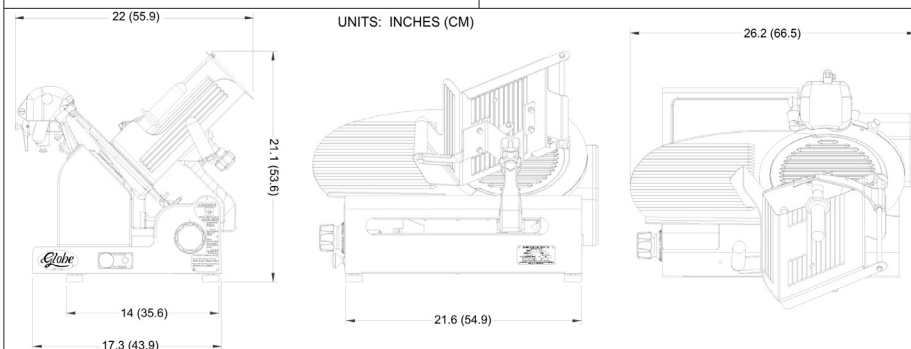

GLOBE FOOD EQUIPMENT COMPANY

www.globeslicers.com

2153 Dryden Rd.
Dayton, OH 45439
Phone: 937-299-5493
Phone: 800-347-5423
Fax: 937-299-4147

Printed in U.S.A. 04-2010

Specifications are subject to change without notice.