

MODEL	WxDxH	DOOR	SHELVES	H.P.	VOLT	WEIGHT
CVK77	77x35x50	2	3	1/2	115	690

***Remote unit price is not including any cooling system assembly parts. (Evaporator only)
SPECIFICATIONS SUBJECT TO CHANGE WITHOUT NOTICE.**



CVK77

FEATURES AND BENEFITS

***Mechanically Controlled Uniform Temperature**

***Excellent Cooling Performance**

Over-sized condenser & evaporator coil keeping food fresh.

*CURVED thermo-pane glass front . thermo-pane glass sliding doors rear

*Welded Base Construction with a Choice of Formica Panel (additional colors available)

***DRY UNIT – NOT WITH THERMO PANE GLASS AND NO ANY COOLING SYSTEM INCLUDED.**

Interior – aluminum sides and stainless steel floor

*Three Level Adjustable Up and Down Epoxy Wire Shelves

*Independently wired Shelf Lights

***Defrost Timer System**

By keeping cooling systems separate from the evaporator, it does not ice up or inhibit the compressor, giving the unit outstanding performance and a long life even in the most difficult environments

***The Famous American Brand “Tecumseh” Compressor**

*Holds 37°F - 40°F

*CVK models are designed to operate in an environment where temperature & humidity do not exceed 75°F and 65% relative humidity.

***Self evaporated water from evaporator (Self-Contain System) No Plumbing Required**

*ETL listed



*Exterior -Stainless steel and & sides formica panel

***MEA City of New York Building Department Approved**

28

FRONT VIEW

MODEL: CVK

SIDE VIEW

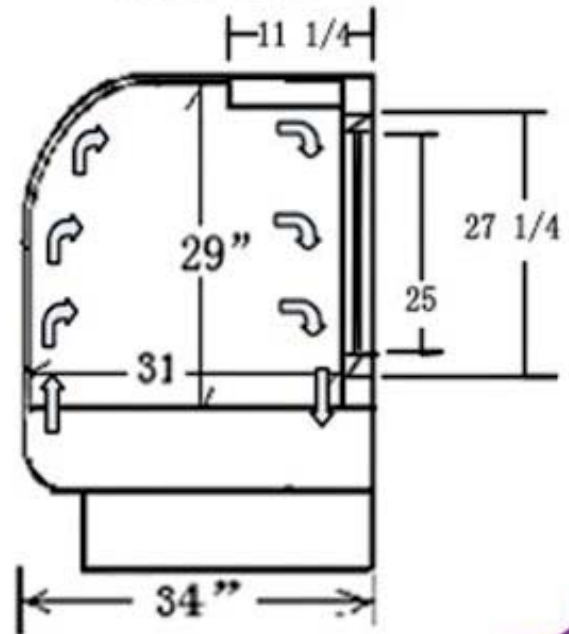
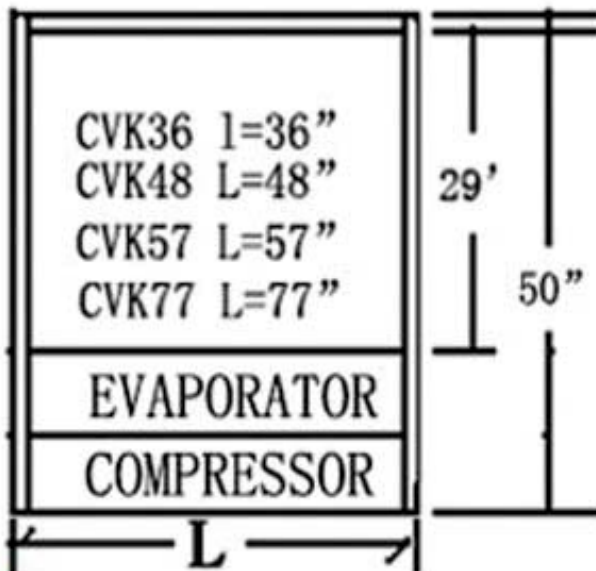

DIAGRAM

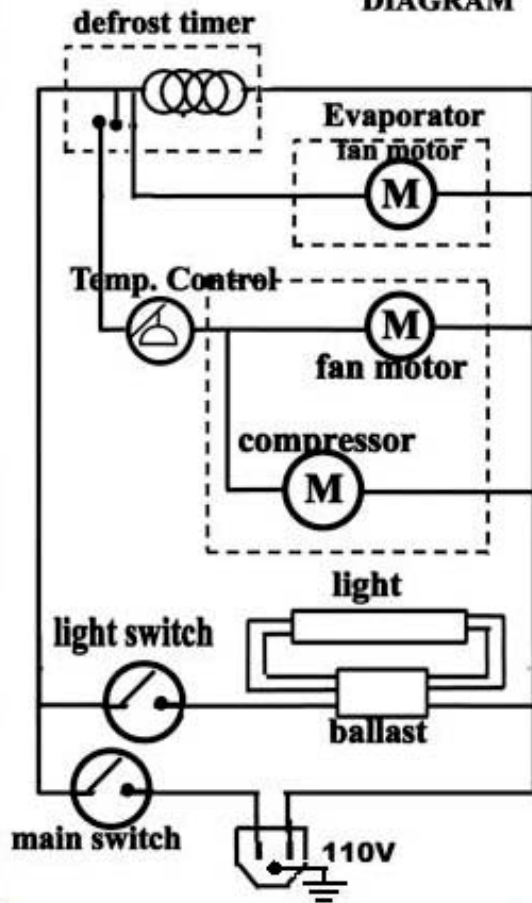

BEST QUALITY

BEST SERVICE

BEST VALUE

SINCE 1992