



SUSS-48-12 DOUBLE DOOR STAINLESS STEEL SANDWICH PREP TABLE



48" DOUBLE DOOR SANDWICH PREP REFRIGERATOR
FEATURES:

- Durable stainless steel doors
- Stainless steel interior and exterior
- Fully balanced self contained refrigeration system
- Easy grab recessed door handles
- High density CFC free polyurethane insulation
- Spring loaded self-closing doors
- Installed 9 ft power cord comes standard
- Environmentally friendly R-134a refrigerant
- Components optimized for smooth quiet operation
- High density cutting board included
- Oversized compressor and coil section
- Heavy duty castors with two front brakes
- Height adjustable shelving for easy storage solutions

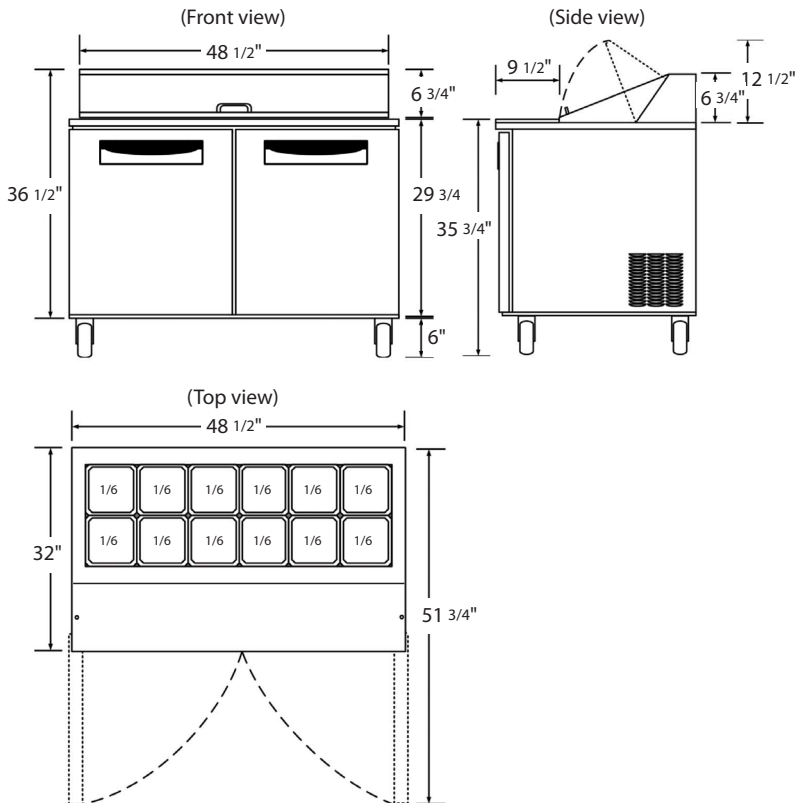

SPECIFICATIONS: SUSS-48-12

Doors	2 Stainless steel swing doors
Capacity cu. ft.	12 Cu. Ft.
Shelves	2 Epoxy coated wire shelves
Compressor	3/8 HP
Pans Included	12 pc @ 1/6th size container
Dimensions	48.25"W x 32"D x 42.5"H
Net Weight	284 lbs
Amps	7.9 A
Power	115V / 60Hz
Power Cord	9 Ft
Temperature	32-40 Degrees F

* In the pursuit of a better product, durability and performance. SATURN reserves the right to change specifications, materials and design without further notice.



Warranty: 2 year parts and labor - 5 year compressor

Tel: 303-801-0680

Fax: 303-801-0681

info@ThinkSaturn.com

www.ThinkSaturn.com