

Reach-In Top Mount

PREMIERE Series

HALF SOLID DOOR FREEZERS

EXCEPTIONAL 3 YEAR PARTS & LABOR WARRANTY



PRO-26-2F



PRO-50-4F



PRO-77-6F

≡ FEATURES & BENEFITS ≡

■ DIGITAL TEMPERATURE CONTROL SYSTEM

Provides precise and constant temperature. This level of precision allows food products to remain fresh over an extended period of time.

■ HIGH-TECH MONITOR

The unit will beep if the door has been opened for more than 30 seconds. The monitor digitally displays the present temperature and current status of the freezer. You can easily change the temperature by adjusting the thermostat.

■ ALL STAINLESS STEEL CABINET CONSTRUCTION

The Turbo Air Premiere model boasts all stainless steel interior and exterior (galvanized steel top, bottom and back). It guarantees the utmost in cleanliness and long product life. Unlike other companies' products, the sharp corners and edges have been rounded to reduce the risk of injury. The Premiere can add a touch of style to the most refined setting.

■ STURDY, CLEAN STAINLESS SHELVING

Shelves are the most important part of cleanliness as they come in direct contact with food. After a while, PVC coated wire shelves may peel, rust and lead to unsanitary conditions. Only the Turbo Air Premiere series uniquely provides stainless shelving.

■ HOT GAS CONDENSATE SYSTEM

Through Turbo Air's creative innovation, the condensate system surfaces have been specially treated to resist corrosion. This not only increases efficiency without the risk of refrigerant leakage from corrosion, but thoroughly prevents the overflow of condensate water.

■ EFFICIENT REFRIGERATION SYSTEM

Premiere's solid door freezers are designed with oversized and balanced (CFC Free R-404A) refrigeration systems. These include efficient evaporators and condensers for faster freezing and greater efficiency.

■ AUTOMATIC EVAPORATOR FAN MOTOR DELAYS

Through stopping the evaporator fan when the freezer door opens, the circulation of hot, moist air into the freezer is prevented. This increases energy efficiency and lengthens the life of the compressor.

■ HIGH-DENSITY POLYURETHANE INSULATION

The entire cabinet structure and solid doors are foamed-in-place using high density, CFC free polyurethane insulation.

■ ERGONOMICALLY DESIGNED DOORS

Customers' fatigue fades away with easy grip handles and doors that open effortlessly. Self-closing and stay open door features make this the ultimate choice in customer convenience.

■ MAGNETIC DOOR GASKETS

Magnetic door gaskets are of one piece construction, removable without tools for ease of cleaning and replacement.

■ TOP MOUNT COMPRESSOR UNITS

Premiere's top mount refrigeration system has positioned the evaporator out of the food zone to maximize capacity.

■ FREEZER HOLDS -10°F ~ 0°F FOR THE BEST IN FROZEN FOOD PRESERVATION

Model	Swing Door	CU./FT.	#of Shelves	HP	AMPS	Crated Weight (lbs.)	L x D x H* (inches)
PRO-26-2F	2	26	3	3/4	7.8	338	28 ³ / ₄ x 33 ⁷ / ₈ x 78
PRO-50-4F	4	50	6	1 ¹ / ₄	10.5	490	51 ³ / ₄ x 33 ⁷ / ₈ x 78
PRO-77-6F	6	77	9	1 ¹ / ₂	13.8	740	77 ³ / ₄ x 33 ⁷ / ₈ x 78

* Height does not include 5" caster height or 6" optional legs.

PRO-F MODELS SPECIFICATIONS

ELECTRICAL DATA	PRO-26-2F	PRO-50-4F	PRO-77-6F
Voltage †	115/60/1	115/60/1	115/208-230/60/1
Plug Type †	Ⓜ NEMA-5-15P	Ⓜ NEMA-5-15P	Ⓜ NEMA-L14-20
Full Load Amperes	7.8	10.5	13.8
Compressor HP	3/4	1 1/4	1 1/2
Feed Wires with Ground	3	3	4
Cord Length ft.	9	9	9
Refrigerant	R-404A	R-404A	R-404A
DIMENSIONAL DATA			
# of Doors	2	4	6
# of Racks Accepted	1	2	3
Net Capacity cu. ft.	26	50	77
Ext. Length Overall in.	28 3/4 (730mm)	51 3/4 (1314mm)	77 3/4 (1975mm)
Ext. Depth Overall in.	33 7/8 (861mm)	33 7/8 (861mm)	33 7/8 (861mm)
Ext. Height Overall in.*	78 (1981mm)	78 (1981mm)	78 (1981mm)
Int. Length Overall in.	24 3/4 (629mm)	47 3/4 (1213mm)	73 7/8 (1877mm)
Int. Depth Overall in.	27 5/8 (701mm)	27 5/8 (701mm)	27 5/8 (701mm)
Int. Height Overall in.	60 5/8 (1539mm)	60 5/8 (1539mm)	60 5/8 (1539mm)
Gross Weight lbs.	338	490	740
# of Shelves	3	6	9
Shelf Size (LxD) in.	26 1/2 x 23 3/4	26 1/2 x 23 1/8	26 1/2 x 25 1/4 26 1/2 x 23 1/8 26 1/2 x 25 1/4

Design and specifications subject to change without notice.
 Actual shipping weight may differ due to extra packing materials for product protection.
 * Height does not include 5" caster height or 6" optional legs.
 † PRO-77-6F requires 115/208-230/60Hz, single phase, 3 pole, 4 wire circuit. (NEMA-L14-20)

- INCANDESCENT INTERIOR LIGHTING
- MINIMUM WATTAGE HEATER IN CABINET FRAME
- DOOR LOCKS
- SELF-CONTAINED SYSTEM
- 4" SWIVEL CASTERS
- SOLID AND STURDY GRILLE DESIGN
- LEGS AVAILABLE FOR ALL MODELS (OPTIONAL)
- TRAY RACK AVAILABLE (OPTIONAL)

■ **WARRANTY :** Exceptional 3 Year Parts and Labor Warranty
 Additional 2 Year Warranty on Compressor

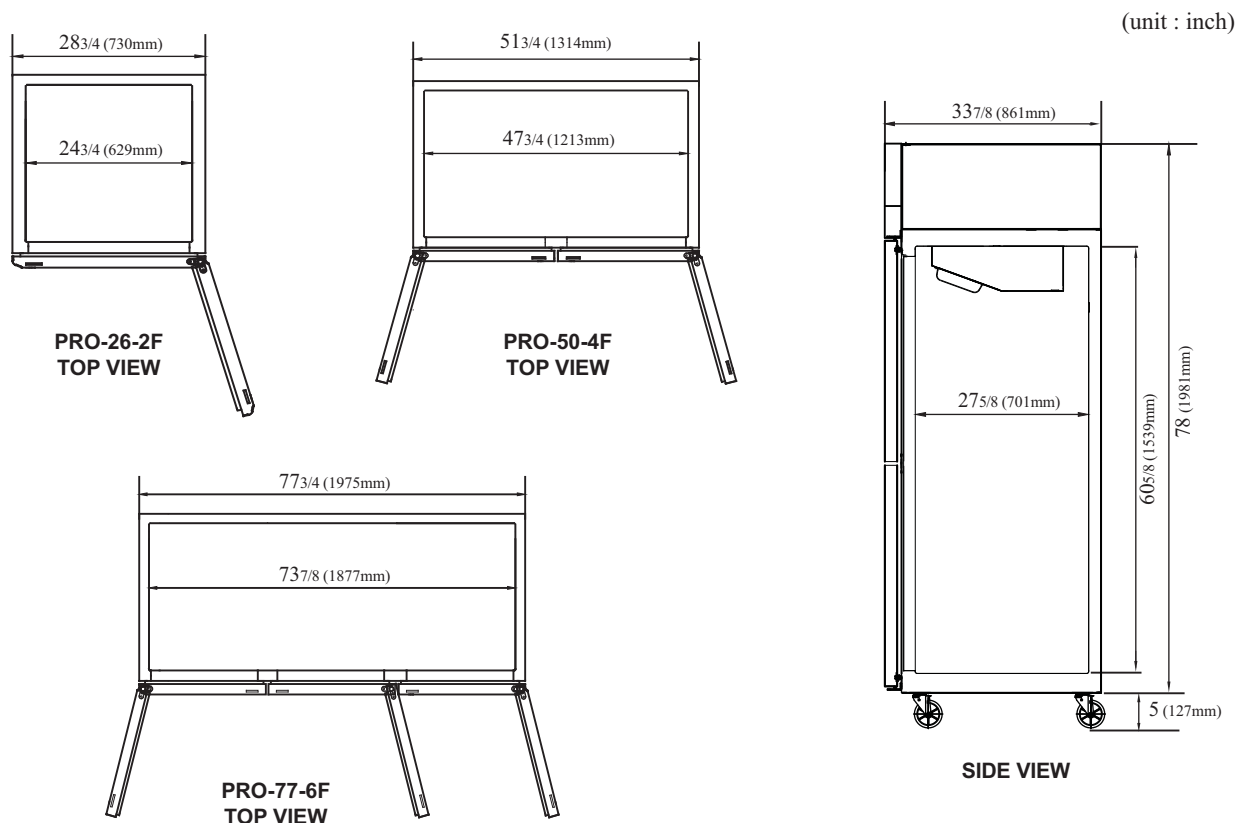

PLAN VIEW