

TURBO AIR REFRIGERATOR MANUFACTURER
Turbo air
 more durable, convenient, beautiful

1250 Victoria St
 Carson, CA 90746
 Tel. 310-900-1000
 Fax. 310-900-1077
www.turboairinc.com

Project :	
Model # :	
Item # :	Qty :
Available W/H :	
Approval :	

Pizza Prep Table - Drawers

Food Prep Tables-Pizza Prep
 Super Deluxe Series

Model : TPR-44SD-D2

**EXCEPTIONAL 3 YEAR
 PARTS & LABOR WARRANTY**



- Drawer pans not included.

≡ FEATURES / BENEFITS ≡

■ STAINLESS STEEL CABINET CONSTRUCTION

The Turbo Air Super Deluxe model boasts a stainless steel interior and exterior (galvanized steel back & bottom). It guarantees the utmost in cleanliness and long product life. The Super Deluxe can add a touch of style to the most refined setting.

■ DURABLE STAINLESS STEEL DRAWERS

Drawers are easy to clean and assemble.

■ EXTRA DEEP CUTTING BOARD

Our cutting board is 19 1/4" deep and 1/2" thick to provide ample working space, and is made of easy to use and sanitize LDPE (Low Density Polyethylene). The new side rail cutting board bracket makes it easy to secure and remove the cutting board.

■ FRONT BREATHING, SIDE MOUNT COMPRESSOR UNIT

Through positioning the compressor to the side, the refrigerator can be serviced without being moved. By innovatively creating a **front breathing** feature, this model can provide high efficiency in narrow spaces.

■ INSULATED PAN COVER

■ HIGH-DENSITY POLYURETHANE INSULATION

The entire cabinet structure and solid doors are foamed-in-place using high density, CFC free polyurethane insulation.

■ EFFICIENT REFRIGERATION SYSTEM

Turbo Air's solid door refrigerators are designed with oversized and balanced (CFC Free R-134A) refrigeration systems. These include efficient evaporators and condensers for faster cooling and greater efficiency.

■ EXCELLENT COOLING SYSTEM

The powerful forced-air refrigeration system maintains the storage cabinet at a constant temperature. The evaporator fan and a newly designed stainless steel louver allow uniform distribution of cold air over the food pans and throughout the unit to keep food fresher longer.

■ HEAVY DUTY STAINLESS STEEL DRAWERS

Durable stainless steel drawers include stainless steel liners and drawer frames. Customers' fatigue fades away with recessed handles and easy gliding rollers. Each drawer can hold two(2) full size (12"L x 20"W x 8"D) food pans. (Food pans and divider bars sold separately)

■ MAGNETIC DOOR GASKETS

Magnetic door and drawer gaskets are of one piece construction, removable without tools for ease of cleaning and replacement.

■ REFRIGERATOR HOLDS 33°F ~ 41°F FOR THE BEST IN FOOD PRESERVATION



Model	Swing Door	Drawers	CU./FT.	#of Shelves	#of Pans	HP	AMPS	Crated Weight (lbs.)	L x D* x H† (inches)
TPR-44SD-D2	-	2	14	-	6	1/4	6.3	321	44 x 32 1/4 x 36

Model : TPR-44SD-D2

ELECTRICAL DATA	
Voltage	115/60/1
Plug Type	Ⓜ NEMA-5-15P
Full Load Amperes	6.3
Compressor HP	1/4
Cord Length ft.	9
Refrigerant	R-134A
DIMENSIONAL DATA	
Ext. Length Overall in.	44 (1118mm)
Ext. Depth Overall in.*	32 1/4 (819mm)
Ext. Height Overall in.†	36 (914mm)
# of Doors	-
# of Shelves	-
# of Pans	6
Net Capacity cu. ft.	14
Gross Weight lbs.	321
Net Weight lbs.	266

Design and specifications subject to change without notice.
Actual shipping weight may differ due to extra packing materials for product protection.
* Depth does not include 3" for cutting boards and 1" for rear spacers.
† Height does not include 5-7/8" for caster height.

- **WARRANTY :** Exceptional 3 Year Parts and Labor Warranty
Additional 2 Year Warranty on Compressor
- SELF-CONTAINED SYSTEM
- 4" DIA. SWIVEL CASTERS
- STANDARD 1/3 SIZE, 6" DEEP CONDIMENT PANS INCLUDED (TOP OF CABINET)
- 19 1/4" DEEP, 1/2" THICK CUTTING BOARD INCLUDED
- 2.5" DIA. CASTERS AVAILABLE (OPTIONAL)
- **OPTIONAL ACCESSORIES :**
 - 2.5" Diameter casters
 - 5" Diameter casters
 - 6" ABS plastic legs
 - Stainless steel single over-shelf

PLAN VIEW

(unit : inch)

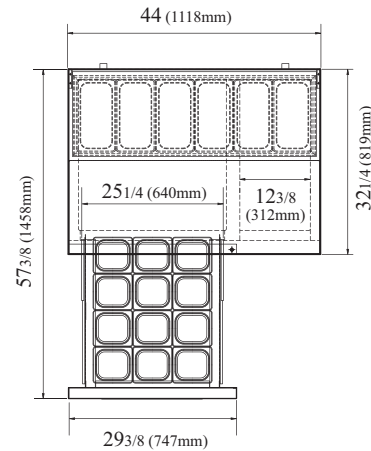

PLAN VIEW

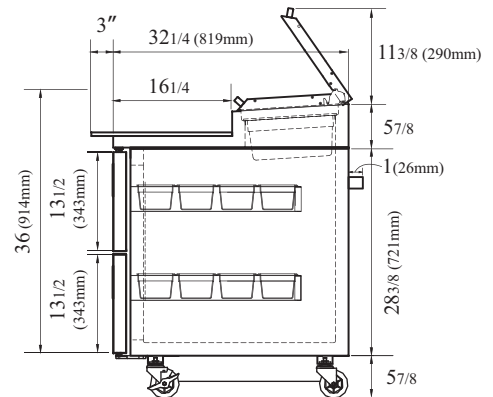

SIDE VIEW

Ver.201301



- Turbo Air : 800-627-0032
- GK : 800-500-3519
- Warranty : 800-381-7770
- AC : 888-900-1002

