

MODEL	WxDxH	DOOR	SHELF	H.P.	VOLT	FOR 1/6 PAN	WEIGHT	CU.FT.
LM48 S/C	48x32x45	1 1/2	1	1/4	115	18	208	16.2



LM48

### FEATURES AND BENEFITS

- \*Exterior – Stainless Steel front and top
- \*Interior – Aluminum side, Stainless Steel bottom.
- \*Excellent Cooling Performance  
Over-sized condenser & Evaporator  
Keep food fresh.
- \*The Famous American Brand  
“Tecumseh” Compressor
- \*Defrost Timer System  
By keeping cooling systems separate from the evaporator, it does not ice up or inhibit the compressor, giving the unit outstanding performance and a long life even in the most difficult environments.
- \*Self-closing door
- \*Adjustable Epoxy Wire shelves  
Durable and Easy to Adjust

- \*5” Casters Standard
- \*Holds 34°F - 40°F

- \*ETL listed



- \*MEA City of New York Building Department Approved
- \*REMOTE UNIT – NOT INCLUDING ANY COOLING SYSTEM ASSEMBLY PARTS. ONLY EVAPORATOR INCLUDED
- \*These models are designed to operate in an environment where temperature & humidity do not exceed 75°F and 65% relative humidity.
- \*Specifications Subject To Change Without Notice

14

FRONT VIEW

MODEL : LM

SIDE VIEW

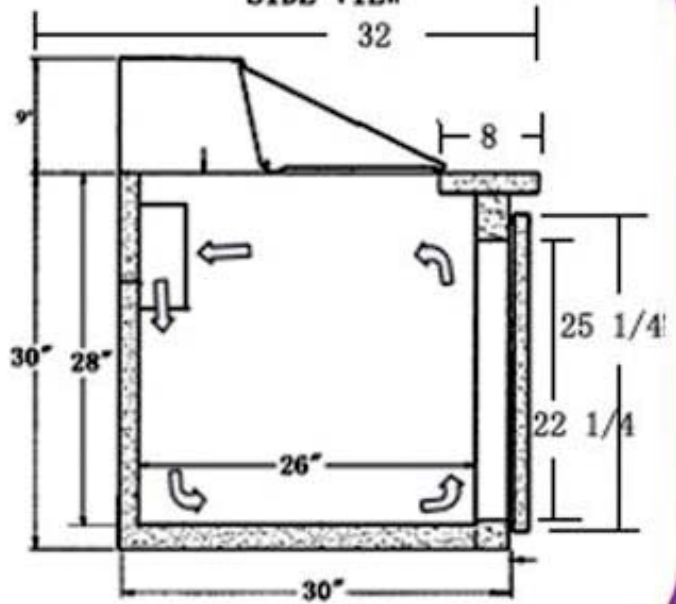
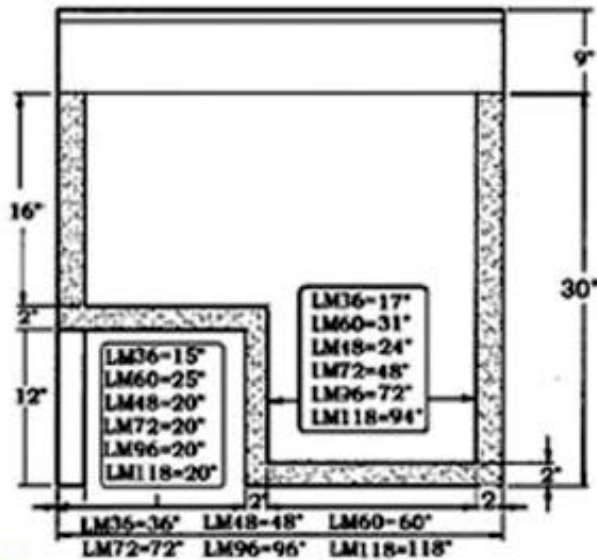

DIAGRAM

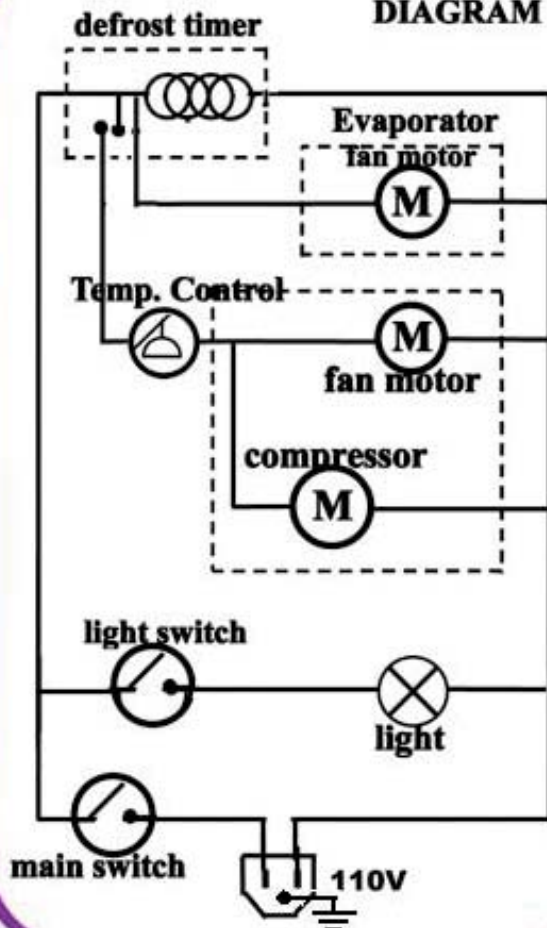

BEST QUALITY

BEST SERVICE

BEST VALUE

SINCE 1992