



## Gravity Feed Bread Slicer

### Key Features:

- Ideal for volume slicing needs of small wholesale, large retail and in-store bakeries
- Blade advantages:
  - Uses the lowest cost replacement blades in the industry, contributing to low cost of ownership-Easily replaceable, independently mounted, rust-resistant blades
  - Blade replacement only takes one hour of labor, the lowest in the industry
- Equipped with a last loaf pusher, and handles up to 200 loaves per hour
- Designed for trouble-free, smooth and quiet operation• Rust and corrosion resistant
- 32" (813mm) or 48" (1,219mm) feed chutes are available
- Combi unit allows for production slicing and on-demand slicing
- Also available with powered in-feed belt
- Available in 16" and 21" widths



Oliver Packaging & Equipment Company  
 511 Sixth Street NW • Grand Rapids, MI 49504  
 (800) 253-3893 • (616) 356-2950 • [www.oliverquality.com](http://www.oliverquality.com)



**Manufactured in the U.S.A.**



# Gravity Feed Bread Slicer

## SPECIFICATIONS:

### Motor:

1/2H.P., single phase, 60Hz, 115 VAC, 7 AMPS  
Special electrics also available

### Length:

Loaves up to 16" (406mm) or 21" (533mm)

### Height:

2 1/4" (57mm) to 5" (127mm)

### Finish:

Stainless steel contact components and food-safe materials throughout

### Slice Spacing:

Standard: 3/8" (10 mm), 7/16" (11 mm), 1/2" (13 mm), 5/8" (16 mm)

Also available at extra cost: 9/16" (14 mm), 11/16" (17mm), 3/4" (19 mm), 13/16" (21mm), 7/8" (22 mm), or 1" (25 mm)

### Optional:

Swing-Away Bagger A hinged mounting attaches the Model 1179S Swing Away Bagger to 16" (406mm) Oliver 797 Gravity Feed Bread Slicers. The bagger swings to the side, giving access to the slicer for cleaning, maintenance or blade change. No separate mounting tables are required, saving valuable floor space. The bagger is 13" (330mm) wide, 41" (1,041mm) long and has a shipping weight of 50 pounds (23kg).

### Dimensions:

	Floor Model 48" Chute (1,219mm)	Floor Model 32" Chute (813mm)	Counter Top Model 32" Chute (813mm)
<b>Shipping Weight</b>			
21" (533mm)	485 lbs (218kg)	Not Available	Not Available
16" (406)	375lbs. (170kg)	300lbs. (135kg)	265lbs. (119kg)
Height:	67" (1,702mm)	56 1/2" (1,435mm)	35 1/2" (902mm)
Width 16" (406mm)	23 3/4" (603mm)	23 3/4" (603mm)	19 5/8" (499mm)
Width 21" (533mm)	29 1/4" (743mm)	Not Available	Not Available
Depth:	49" (1,245mm)	37 1/2" (953mm)	35 1/2" (902mm)

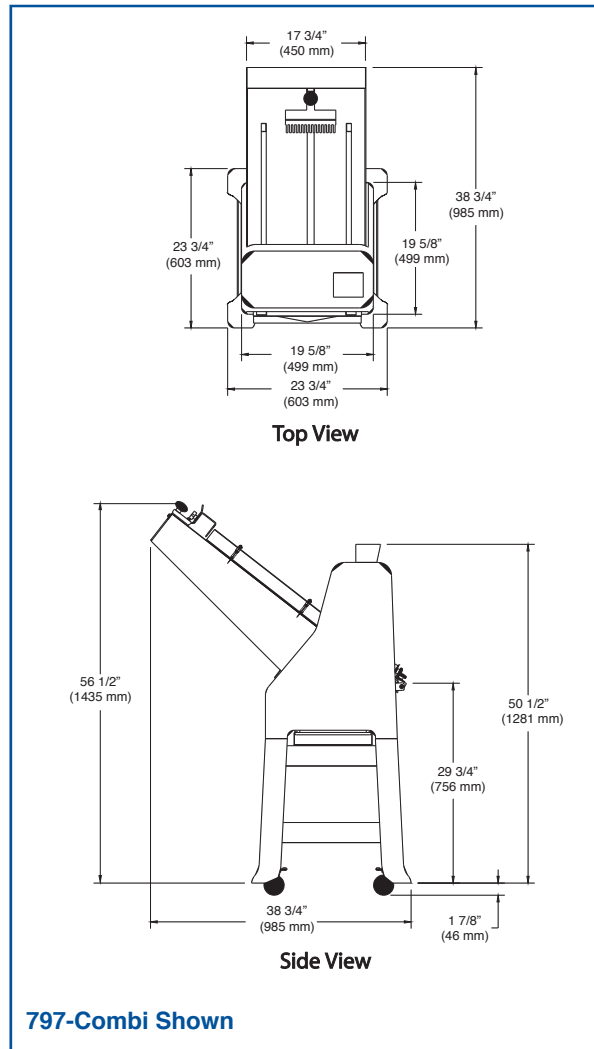

The information contained herein is correct to the best of our knowledge. The recommendations or suggestions are made without guarantee or representation as to results. Freedom from any patent owned by Oliver Packaging and Equipment or other is not to be inferred. Above specifications subject to change without notice

**Manufactured in the U.S.A.**



Oliver Packaging & Equipment Company  
511 Sixth Street NW • Grand Rapids, MI 49504  
(800) 253-3893 • (616) 356-2950 • www.oliverquality.com