

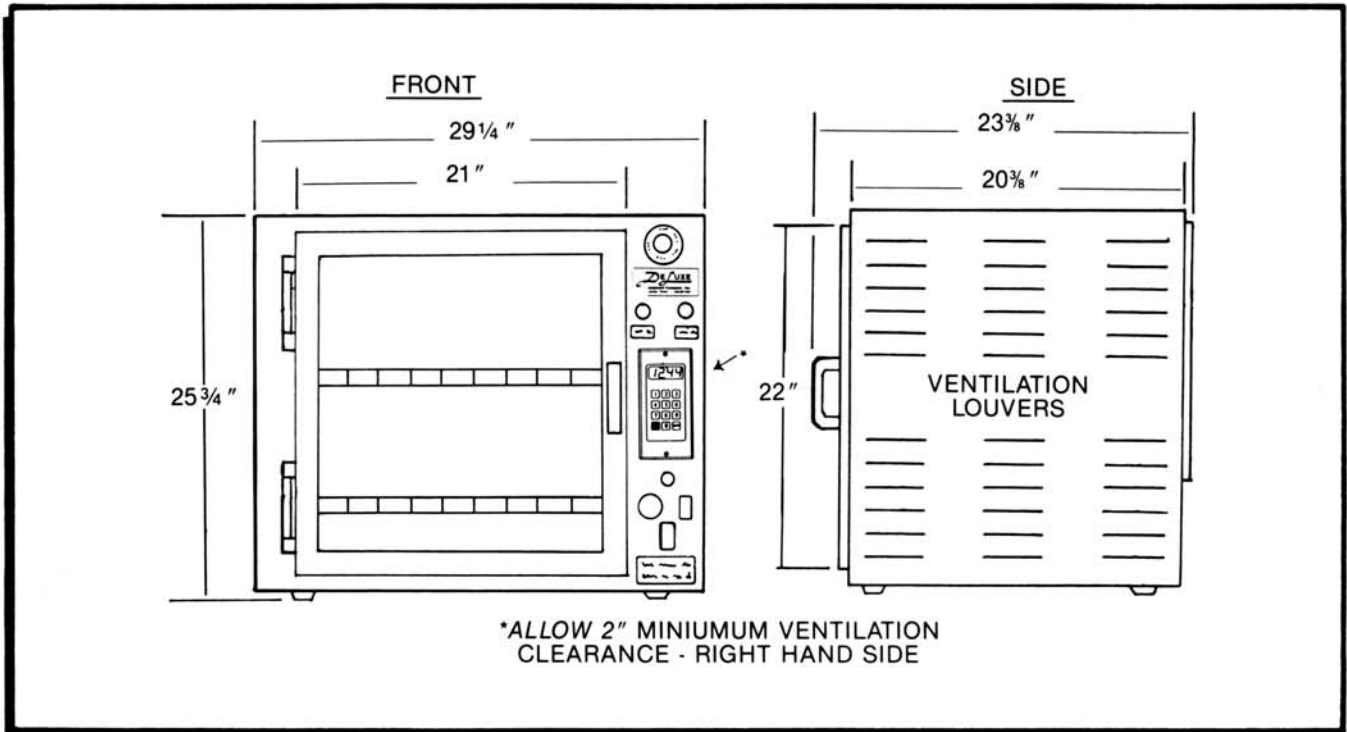

Model CR-1/2

DELI-BAKERY-FOOD SERVICE CONVECT-A-RAY OVEN



SPECIFICATIONS:

Interior Dimensions:

20" Height
 19" Width
 20" Depth

Electrical: 2250 Watts

MODEL #	** VOLTAGE AND PHASE	CONDUCTORS—AMPS/LINE				TOTAL LOAD (AMPS)	TYPE OF CONNECTION
		L1	L2	L3	N		
CR-1/2	120-1-60	19.0	—	—	19.0	19.0	6' Power Cord
	120/208-1-60	11.0	11.0	—	Required	11.0	No Cord Supplied
	120/240-1-60	10.0	10.0	—	Required	10.0	No Cord Supplied

** Please Specify Electrical Requirements when Ordering

WARRANTY: One Full Year on All Parts from Date of Shipment
 Heating Elements Warranted for Life of Unit

SHIPPING WEIGHT: Approximately 118 lbs.

F.O.B. BRADENTON, FLORIDA

Prices and Specifications Subject to Change without Notice

DeLuxe Equipment Co. Inc. • 4414 28th Street West • Bradenton, Florida 34207
 Toll Free 1-800-367-8931 • (941) 753-4184 (in Florida) • FAX (941) 753-4529

“ . . . making the BEST ovens even BETTER!”