

## MP 350 Turbo Combi, MP 450 Turbo Combi, & MP 450 FW

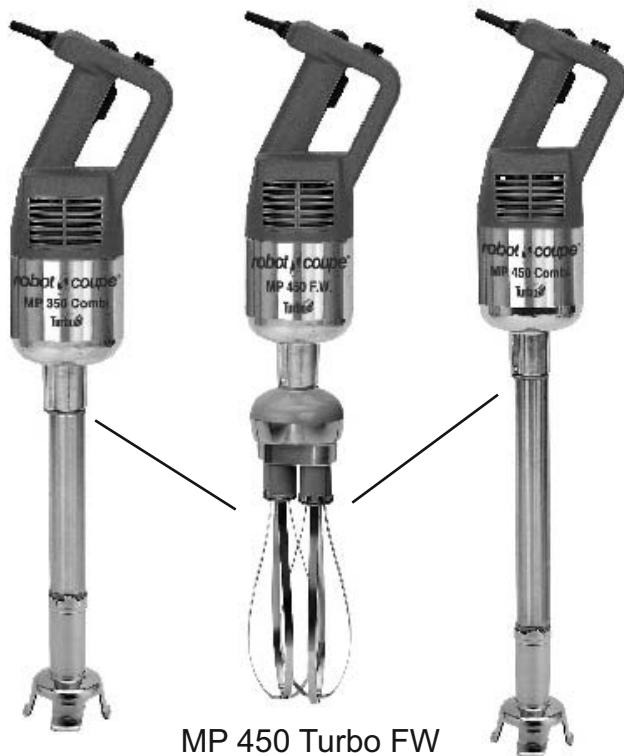

MP 350 Turbo Combi

MP 450 Turbo Combi

MP 450 Turbo FW

Combi Models come with Mixing attachment and Whisk attachment. FW model comes with Whisk attachment only.

- Power: Single phase.  
MP 350 Turbo Combi:  
1 HP/660 Watts  
MP 450 Turbo Combi &  
MP 450 Turbo FW:  
1.1 HP/720 Watts
- Variable speed:
  - from 2300 to 18000 rpm (mixer attachment)
  - from 500 to 1500 rpm (whisk attachment).
- Speed self regulation system.
- 100% stainless steel removable bell, New tube design with stainless steel tube bearings for longer life expectancy, improved watertightness, and quick repair concept.
- Extended Stainless Steel Data Plate.
- MP 350 Turbo Combi:
  - Shaft length: 14"
  - Whisk length: 10"
- MP 450 Turbo Combi:
  - Shaft length: 18"
  - Whisk length: 10"
- MP 450 Turbo FW:
  - Whisk length: 10"
- 1 Year "No Hassle" Replacement Warranty.
- ETL Electrical and Sanitation listed/CETL (Canada).

Turbo Combi Power Mixers are ideal for liquefying soups, sauces, pureeing fruits and vegetables with a portable, easy to handle unit.



Robot Coupe U.S.A., Inc.

P.O. Box 16625

Jackson, MS 39236-6625

1-800-824-1646 • (601) 898-8411

FAX: (601) 898-9134

www.robotcoupeusa.com • e-mail: info@robotcoupeusa.

"The Inventor & World Leader in Food Processors"

## Specifications

**STANDARD MODEL:** Variable Speed Power Mixer with stainless steel mixer attachment with removable stainless steel knife (FW model comes with whisk attachment only), mixer blade, stainless steel whisk attachment, splash guard and blade disassembly tool.

**ELECTRICAL REQUIREMENTS:** 120V, 60HZ, single phase

**SWITCHING:** "On/Off control button, variable speed control, lock button for continuous operation, safety button.

**MOTOR:**  
 MP 350 Turbo Combi: 1 HP, 660 Watts, Single Phase, Variable Speed 3000 to 10000 rpm (mixer attachment), 500 to 1800 rpm (whisk attachment).  
 MP 450 Turbo Combi & FW Model: 1.1 HP, 720 Watts, Single Phase, Variable Speed 2300 to 10000 rpm (mixer attachment for MP 450 Turbo Combi only), 500 to 1800 rpm (whisk attachment).

**SHIPPING WEIGHT:**  
 MP 350 Turbo Combi - 19 lbs  
 MP 450 Turbo Combi - 20 lbs  
 MP 450 Turbo FW - 14 lbs

**STANDARDS:** ETL electrical & sanitation, cETL (Canada)

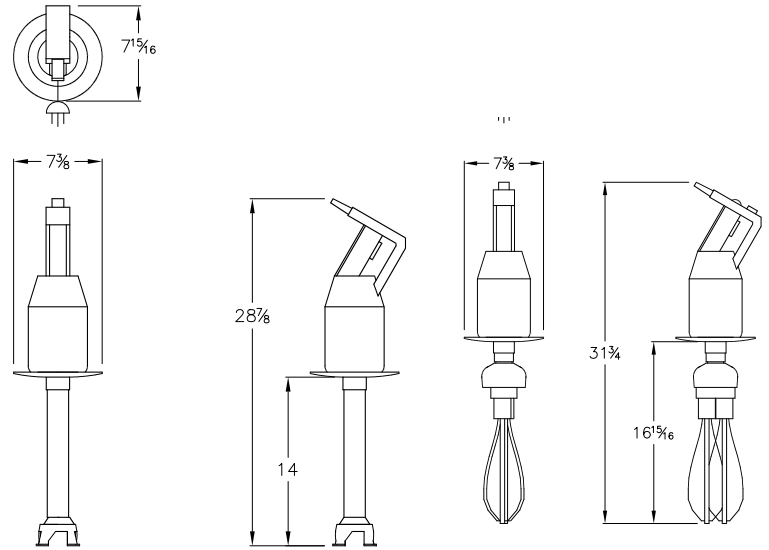

MP 350 Turbo Combi

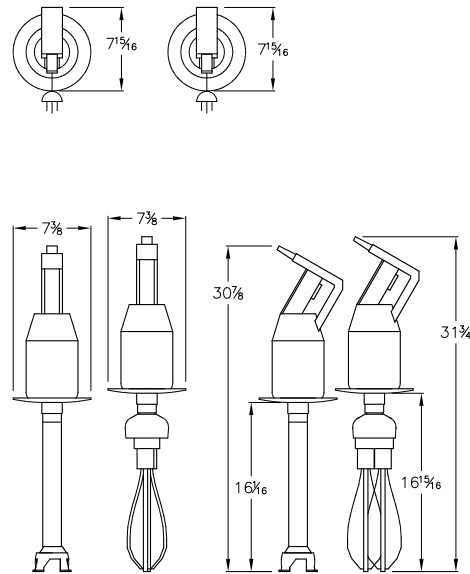

MP 450 Turbo Combi

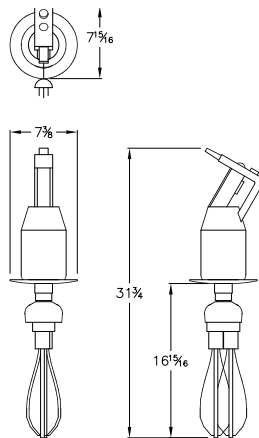

MP 450 Turbo FW

Ref #121106

Robot Coupe U.S.A., Inc.  
 P.O. Box 16625  
 Jackson, MS 39236-6625  
 1-800-824-1646  
 (601) 898-8411  
 FAX: (601) 898-9134  
 www.robotcoupeusa.com  
 e-mail: info@robotcoupeusa.com

Distributed by: