

ERIKA Semi-Automatic Bun Divider/Rounders



ERIKA offers the widest selection of top quality divider/rounders in the industry. This broad selection of models, coupled with their more gentle rounding action, enables you to produce a great deal more than the regular line of buns and rolls. Now you can include such products as:

- Portuguese Rolls (Choose a model to 4 ounces or higher)
- Airy French Rolls (Ideal with the 20- or 30-part model)
- Flour Tortillas (Get more production with a 50-part machine)
- Miniature Breads or Individual Sized Pizza (Choose from a 7- or 15-part divider unit)

ERIKA divider/rounders are also ideal for only dividing doughs for pies, tarts, and specialty rolls.

Considering their versatility, reliable performance, and superior construction, **ERIKA** divider/rounders are the most durable and the best choice for a wide range of operations including retail, artisan, or in-store bakeries, restaurants, pizza shops, hotels or commissaries, hospitals, college or prison food facilities.

ERIKA machines take away the laborious task of dividing and rounding doughs by hand, making the entire process faster, easier, and simpler. Better yet, you'll be assured of uniformity in dough weight and shape, time after time. What's more, the quick release design of the front and rear covers and embracing ring make cleaning quick and easy.

In an effort to continuously improve our products, the company reserves the right to change specifications and dimensions without notice. Dough capacities are approximate and depend on dough consistency.

Models	Capacities			Weights		Crate Dimensions
	Number of Parts	Weight of individual dough pieces in ounces	Total Weight range in lbs.	Net lbs.	Ship.Wt. lbs.	
9/20	36	0.7 - 2.5	1.5 - 5.6	770	880	31"x33"x63"
10/25	36	0.9 - 3.3	2.0 - 7.5	770	880	31"x33"x63"
11/30	36	1.0 - 4.0	2.3 - 9.0	770	880	31"x33"x63"
4/40	30	1.4 - 4.3	2.6 - 8.1	770	880	31"x33"x63"
5/18	50	0.6 - 1.5	1.9 - 4.7	770	880	31"x33"x63"
6/150	15	5.4 - 9.5	5.1 - 8.9	770	880	31"x33"x63"
7/70	2.0	2.5 - 7.1	3.9 - 8.4	770	880	31"x33"x63"
8/250	7	9.0 - 21.0	3.9 - 9.2	770	880	31"x33"x63"

TECHNICAL SPECIFICATIONS:

FEATURES:

- Three light weight, sanitary plastic rounding plates are included
- Machine is shipped with necessary oil for rounding mechanism
- Cutting knives are hot tin plated for sanitary purposes
- Easy weight adjustment
- No oil in, or above, product zone
- Minimum maintenance required
- Rounding mechanism runs in oil bath for absolutely smooth, quiet, and long lasting operation
- Hourly production up to 7,000 pieces (depends on operator efficiency and production flow)

CONSTRUCTION:

- Base, gear housing, arch, and knife frame made of sturdy cast iron
- Finish is a lead-free enamel paint
- Head covers in front and rear are of durable thermoplastic material, impact resistant and shatter proof; they snap off and on for fast cleaning
- Rounding plate drive is via a double bearing support
- Head can be tilted to left or right side for easy cleaning; dough embracing ring comes off in seconds

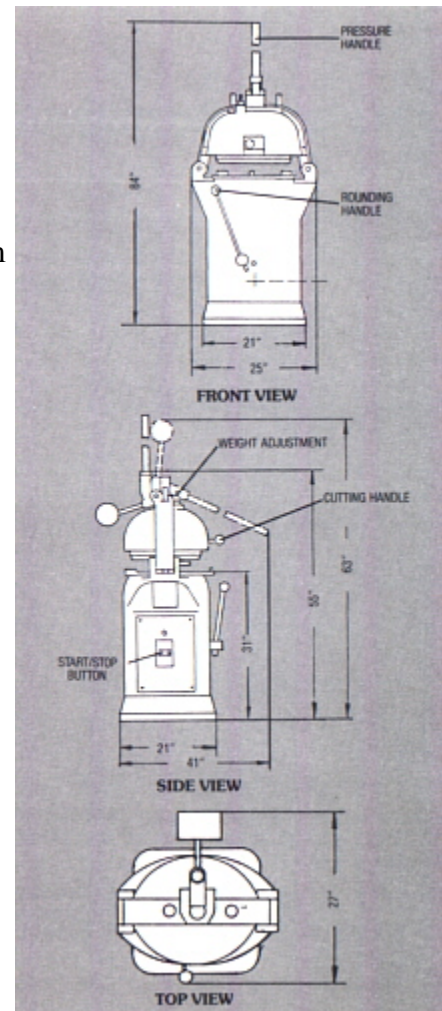

ELECTRICAL:

- Manual motor start with built-in thermal overload protector
- On/off switch for motor on left side base panel
- Machine comes with 12 foot main cable
- Electrical requirements: 220 volts, 3 phase, 60 cycles; 3/4 HP motor, 3.0 amps, 0.55 KW

APPROVALS:

- ETL Listed to meet UL, NSF and CSA standards
- BISSC (Baking Industry Sanitation Standard Committee) approved

OPTIONS:

- 1-phase version, 60 cycles, 220 volts available
- 50 cycle machines and other voltages also available on request
- Machine on wheels
- Stainless steel knives and aluminum head assembly
- Prison packages available