

**REFRIGERATOR MANUFACTURER**  
**Turbo air**  
 more durable, convenient, beautiful

1250 Victoria St  
 Carson, CA 90746  
 Tel. 310-900-1000  
 Fax. 310-900-1077  
[www.turboairinc.com](http://www.turboairinc.com)

Project :	
Model # :	
Item # :	Qty :
Available W/H :	
Approval :	

## Glass Door Freezer

Glass Door Merchandisers  
Freezers

**Model : TGF-23F  
TGF-23FB**

### FEATURES / BENEFITS

- DIGITAL TEMPERATURE CONTROL SYSTEM**  
 Provides precise and constant temperature. This level of precision allows food products to remain fresh over an extended period of time.
- HIGH-TECH MONITOR**  
 The unit will beep if the door has been opened for more than 30 seconds. The monitor digitally displays the present temperature and current status of the freezer. You can easily change the temperature by adjusting the thermostat.
- EFFICIENT REFRIGERATION SYSTEM**  
 Turbo Air's freezers are designed with oversized and balanced (CFC Free R-404A) refrigeration systems. These include efficient evaporators and condensers for faster freezing and greater efficiency.
- AUTOMATIC EVAPORATOR FAN MOTOR DELAYS**  
 Through stopping the evaporator fan when the freezer door opens, the circulation of hot, moist air into the freezer is prevented. This increases energy efficiency and lengthens the life of the compressor.
- TRIPLE PANE HEATED GLASS DOORS WITH HEAT REFLECTING FILM**  
 Equipped with unique triple pane heated glass doors with a layer of patented, transparent thermal insulating film applied between the glass layers. Lightweight door construction reduces door maintenance and roller wear, and facilitates smooth door opening.
- ADJUSTABLE, HEAVY DUTY, PE (POLYETHYLENE) COATED WIRE SHELVES**
- HIGH-DENSITY POLYURETHANE INSULATION**  
 The entire cabinet structure is foamed-in-place using high density, CFC free polyurethane insulation.
- TASTEFUL AND MODERN APPEARANCE**  
 The design of our products is one of our top priorities. Whether you have a restaurant, bar, convenience store or gas station, Turbo Air refrigerators will compliment the appearance of your operation.
- ERGONOMICALLY DESIGNED DOORS**  
 Customers' fatigue fades away with easy grip handles and doors that open effortlessly. These features along with self-closing doors make this the ultimate choice in customer convenience.
- MAGNETIC DOOR GASKETS**  
 Magnetic door gaskets are of one piece construction, removable without tools for ease of cleaning and replacement.
- BOTTOM MOUNT COMPRESSOR UNITS**  
 Turbo Air's bottom mount compressor allows easier access for service and extra storage space above. In addition, the lower area provides a cooler and less greasy operating environment which results in reduced compressor running time.



**FREEZER HOLDS -15°F ~ 5°F FOR THE BEST IN FROZEN FOOD PRESERVATION**



Model	Swing Door	CU./FT.	#of Shelves	HP	AMPS	Crated Weight (lbs.)	L x D* x H (inches)
<b>TGF-23F(B)</b>	<b>1</b>	<b>23</b>	<b>4</b>	<b>2/3</b>	<b>8.2</b>	<b>376</b>	<b>27 x 29 3/4 x 77</b>

## Model : TGF-23F(B)

ELECTRICAL DATA	
Voltage	115/60/1
Plug Type	 NEMA-5-15P
Full Load Amperes	8.2
Compressor HP	2/3
Cord Length ft.	7
Refrigerant	R-404A
DIMENSIONAL DATA	
# of Doors	1
Net Capacity cu. ft.	23
Ext. Length Overall in.	27 (686mm)
Ext. Depth Overall in.*	29 3/4 (756mm)
Ext. Height Overall in.	77 (1956mm)
Int. Length Overall in.	23 (584mm)
Int. Depth Overall in.	26 1/4 (667mm)
Int. Height Overall in.	60 3/8 (1534mm)
Gross Weight lbs.	376
Net Weight lbs.	355
# of Shelves	4
Shelf Size (LxD) in.	21 3/4 x 22 1/2

Design and specifications subject to change without notice.  
Actual shipping weight may differ due to extra packing materials for product protection.  
\* Depth does not include 1-3/8" for glass door handles.

- **WARRANTY : 2 Year Parts and Labor Warranty  
Additional 3 Year Warranty on Compressor**

- **WHITE AND BLACK COLOR CABINET AVAILABLE**
- **TRIPLE PANE HEATED GLASS DOOR**
- **4" SWIVEL CASTERS AVAILABLE (OPTIONAL)**

■ **OPTIONAL ACCESSORIES :**

- Additional PE coated wire shelves

## PLAN VIEW

(unit : inch)

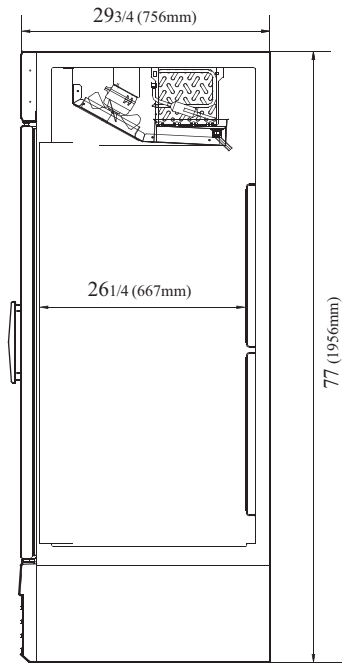
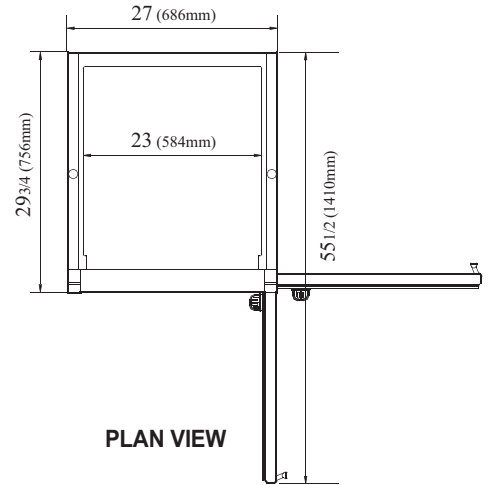

Ver.201301

								<ul style="list-style-type: none"> <li>■ Turbo Air : 800-627-0032</li> <li>■ GK : 800-500-3519</li> <li>■ Warranty : 800-381-7770</li> <li>■ AC : 888-900-1002</li> </ul>
---	---	---	---	---	---	---	---	---