

BUSH REFRIGERATION

Marc LUBCR/LUBCD Series Lift Up High Volume Curved Glass Refrigerated Bakery For Bush Refrigeration

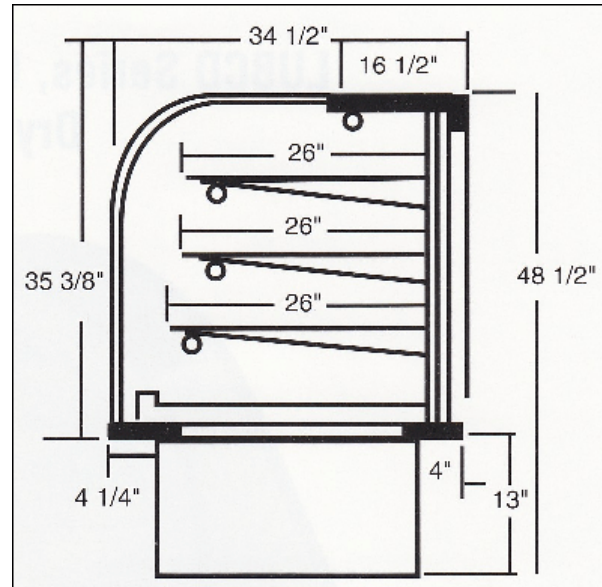

Features

- Lift up front glass
- Curved insulated safety glass (non insulated on LUBCD Models)
- Full length fluorescent lighting installed at top of case and under each shelf
- Three rows of heavy duty white coated wire shelves able to accommodate standard 18" x 26" sheet plates
- Electrical cord and plug
- Mirror interior ends
- Mirror interior sliding doors, white on exterior doors
- Mirror stainless top caps
- Mirror stainless steel front grill on LUBCR Models
- Heavy duty aluminum mill finish main deck
- Condensate evaporator eliminates need for drain on Refrigerated Models

Model No.	Height	Length	Depth	Top Access Doors	Hp	Voltage	Amps	Est Ship Wt
LUBCR-48	48½"	49½"	34½"	2	1/3	120/60/1	12	665
LUBCD-48	48½"	49½"	34½"	2	-	120/60/1	3	470
LUBCR-59	48½"	60½"	34½"	4	1/2	120/60/1	16	780
LUBCD-59	48½"	60½"	34½"	4	-	120/60/1	3	680
LUBCR-77	48½"	78½"	34½"	4	1/2	120/60/1	16	970
LUBCD-77	48½"	78½"	34½"	4	-	120/60/1	3	840

NOTE: Designed for use in locations with air conditioning where temperature and relative humidity do not exceed 75° F and 55% RH. (Excessive condensation & loss of temperature may occur).

We reserve the right to change specifications and or colors of interior and or exterior parts at our own discretion without notice.

Bush Refrigeration

1-877-907-8387 • Fax: 856-963-0770 • Contact: info@bushrefrigeration.com • Website: www.bushrefrigeration.com